

How to Select the Right eSATA Connector and Cable



External SATA (eSATA) applications range from a single disk external drive to multi-disk external storage/backup with RAID/Port multiplier features. New generation Set top box (STB) and motherboard (MB) product releases have also added eSATA connectors. The market demand for eSATA external storage is on the rise.

eSATA components must address the following issues:

1. Prevent ESD (Electro-static Discharge) damage during connector plugging.
2. Comply with EMI (Electro-magnetic Interference) limits per FCC and CE regulations.
3. Withstand the more frequent insert/removal cycles (called durability) by the users.

The selection and implementation of eSATA connectors and cables during the design phase is critical. It is essential to consider both the eSATA connector and cable. The products themselves must meet SATA-I/O specified requirements. Such products provide the highest degree of interoperability and ease of implementation through compliance with mechanical tolerance, mated impedance, and cable connector shielding. Products supplied by companies who are members of SATA I/O and have been involved with the design and verification of the standard are excellent choices.

What are the differences of eSATA connectors versus SATA internal connectors?

1. The External connector has no "L" shaped key.

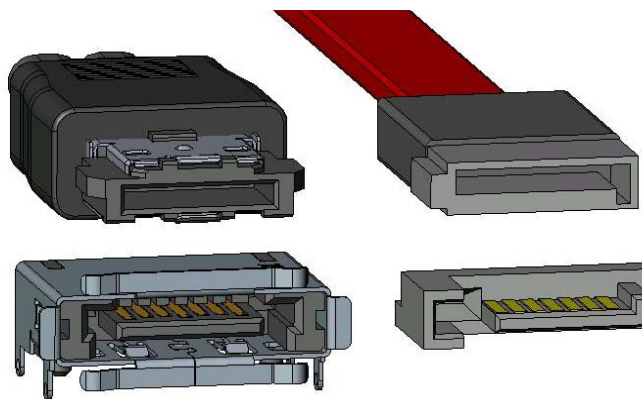

eSATA connectors

Standard internal SATA connectors

2. The guide features have been changed to prevent the use of unshielded SATA internal cables in external applications and assist the alignment with the mating connector.
3. Anti-USB key features are included to prevent USB cable insertion.
4. The insertion depth is increased from 5mm to 6.6mm to provide a more robust interconnect.
5. Full shielding to reduce EMI to provide an ESD path.
6. The contacts are recessed in both the receptacle and plug to prevent ESD damage.
7. Increased durability to 2500 cycles.

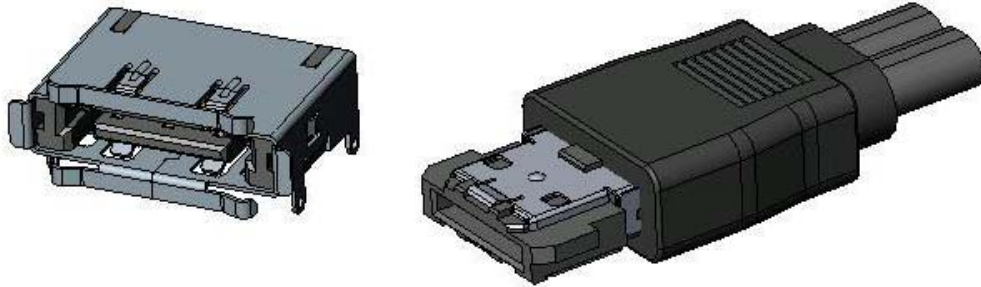

What are the differences of eSATA cables versus SATA internal cables?

1. Fully-shielded cable with separation of the outer shielding (for chassis ground) and signal ground.
2. Hot-plugging supported.
3. Maximum length increased to 2 meters.
4. The external cable electrical parameter requirements are different from internal (xx) requirements as shown below:

A.	Maximum insertion loss (10-4500MHz)	8db	(6dB)
B.	Maximum rise time (35ps input)	150ps	(85ps)
C.	Maximum intra-pair skew	20ps	(10ps)

Considerations for connector selection:

There are 4 basic types of connectors.

1. Right angle surface mount
2. Right angle surface mount with reverse pinout
3. Vertical surface mount

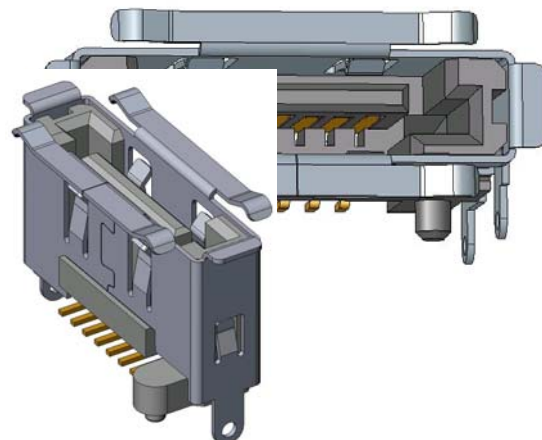
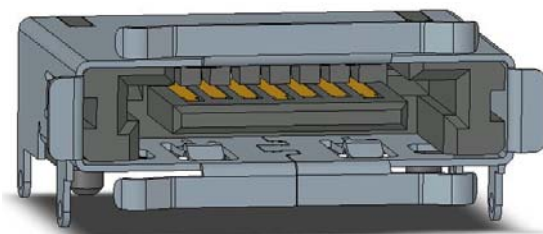

4. Vertical through hole

During selection of the right angle surface mount connector, check the pin assignment of the integrated circuit (IC) that the connector will be used with. A reverse configuration is available so that the connector chosen can align with the IC pinout to avoid crossing traces on the printed circuit board layout. The post size and location of the right angle surface mount reverse connector is different than the right angle surface mount connector to prevent installation of the wrong type.

Implementation considerations:

The spring in front edge should be connected to chassis ground.

The shielding requires a good electrical connection to the shell of cable connector to reduce EMI and ESD issues.

Check the mated connector impedance and impedance discontinuities. These are important items for high-speed signaling.

Review the compliance test report for the connector and cable.

Review performance parameters to ensure the cable conductor size is suitable for the length.

Verify the system performance.

For additional information regarding ESD issues, refer to the following information:

http://www.sata-io.org/docs/ESD_control_for_eSATA_a02-RC-1.pdf